

190-603

RULES FOR SAFE OPERATION

Any power equipment can cause injury if operated improperly or if the user does not understand how to operate the equipment.
Exercise caution at all times when using power equipment.

Refer to your tractor owners manual for "Rules For Safe Operation."



LOOK FOR THIS SYMBOL TO POINT OUT IMPORTANT SAFETY PRECAUTIONS. IT MEANS --- ATTENTION! BECOME ALERT. YOUR SAFETY IS INVOLVED.

1. Place the plug on a work bench or a solid table. Set the end of the bumper onto the plug so that it rests on the short step of the plug. Using even pressure, push down on the bumper tube until the end of the bumper slips over the plug. See figure 1. Repeat for the other end of the bumper.

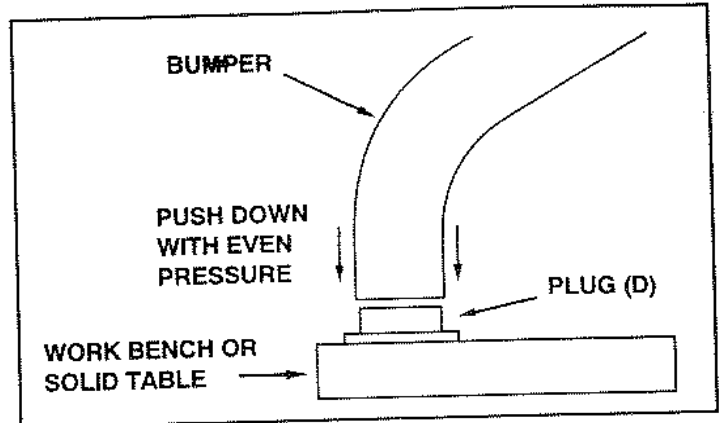

FIGURE 1



CAUTION!
MUFFLER IS HOT! MAKE SURE ENGINE HAS COOLED DOWN BEFORE INSTALLING BUMPER.

ASSEMBLY INSTRUCTIONS

CARTON CONTENTS

1. (A) Bumper Tube Assembly (Fig. 2)
2. Hardware Package (below)

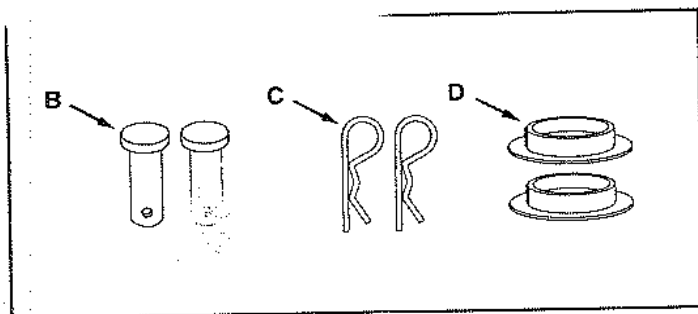

HARDWARE PACKAGE

2. To mount the bumper to the tractor, hook the notched ends of the bumper (A) onto the shoulder bolts on the sides of the tractor frame. Align the holes in the bumper with the holes in the tractor frame and insert the clevis pins (B) through the aligned holes. Secure the pins in place with the hair cotter pins (C). See figure 2.

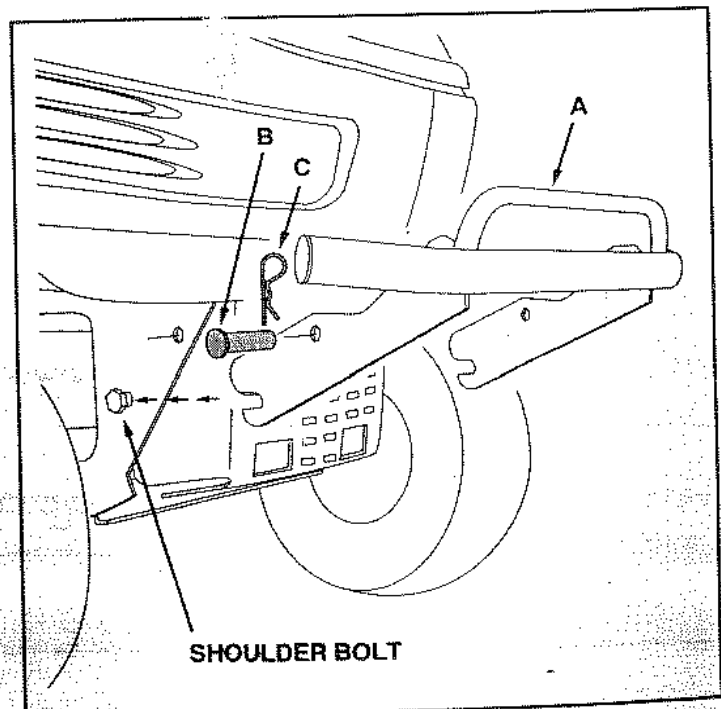

FIGURE 2

REPAIR PARTS FOR MODEL OEM-190-603

REF. NO.	PART NO.	QTY.	DESCRIPTION
A	47442	1	Bumper Assembly
B	44056	2	Clevis Pin, 1/2" x 1"
C	43055	2	Hair Cotter Pin, 3/32"
D	44742	2	Plug