

514728
324-0500

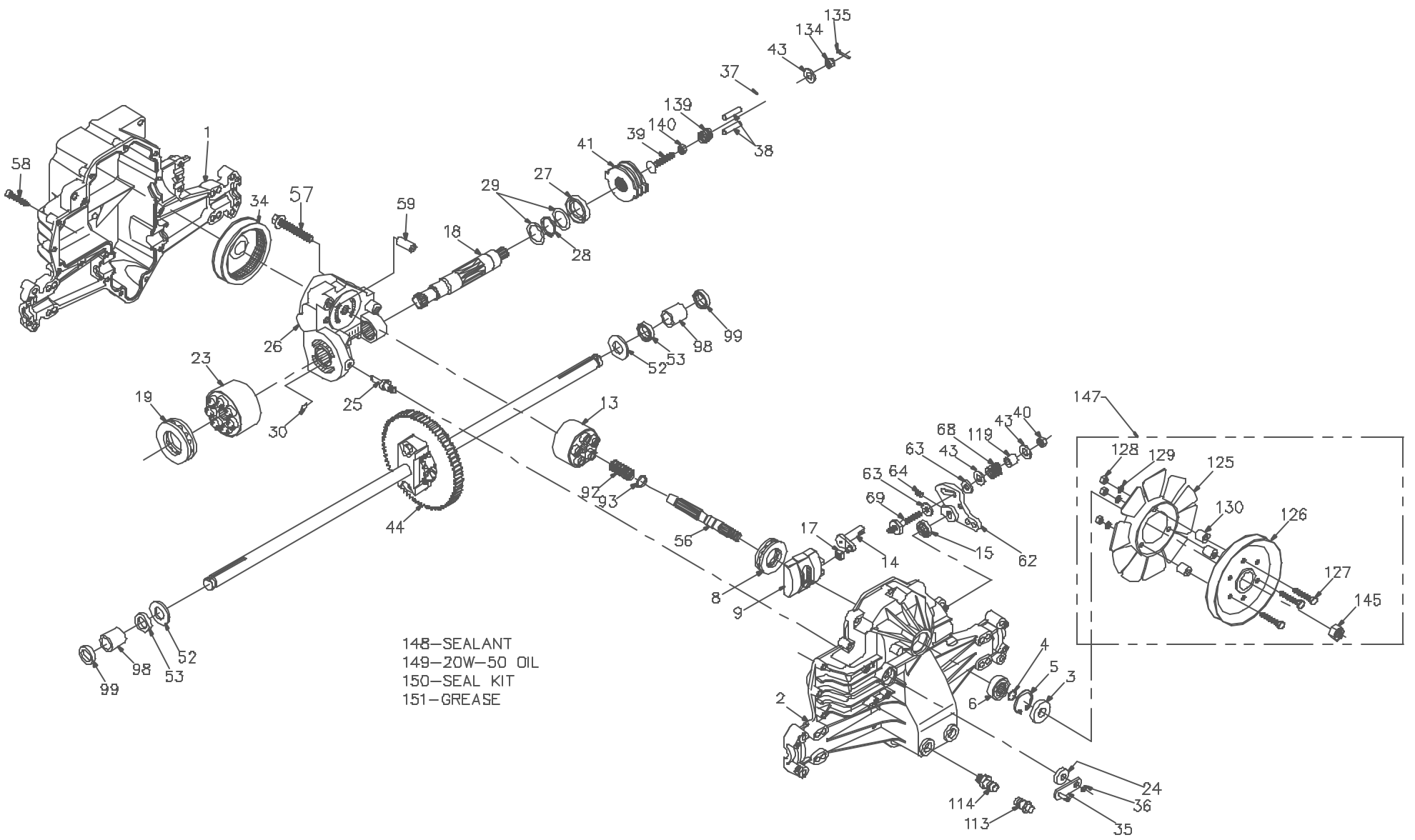

148-SEALANT
149-20W-50 OIL
150-SEAL KIT
151-GREASE



P.1 of 2. 70419-S1

514728
324-0500

ITEM NO	HYDR-GEAR PART NO	QTY	DESCRIPTION	ITEM NO	HYDR-GEAR PART NO	QTY	DESCRIPTION
1	44863RM	1	HOUSING, LOWER	43	44130	3	WASHER-7/16 X 7/8 X .060
2	70254	1	ASSEMBLY, UPPER HOUSING	44	70417	1	DIFFERENTIAL ASSEMBLY
		1	LIPPER HOUSING			2	AXLE SHAFT
		1	TRUNNION JOURNAL BEARING			1	72T DIFFERENTIAL GEAR
3	9008000-012B	1	SEAL-LIP			2	DIFFERENTIAL HDUSING
4	2003016	1	RING-WIRE RETAINING			2	14T BEVEL GEAR
5	2003052	1	RING-RETAINING			2	10T PLANET GEAR
6	2003043	1	BEARING-SHAFT BALL			2	RETAINING RING
8	50551	1	BEARING-THRUST 30X52X13			2	DIFFERENTIAL LOCKING BOLT
9	2003087	1	SWASHPLATE-VARIABLE			1	DIFFERENTIAL SPACER
13	70331	1	BLOCK-CYLINDER ASS'Y.	52	44875	2	WASHER-3/4 X 1.5 X .13
		1	BLOCK-CYLINDER	53	45076	2	SEAL-.75 X 1.25 X .250
		5	PISTON	56	50005	1	SHAFT-INPUT
		5	PISTON SPRING	57	50016	3	BOLT, 3/8-24 X 2.5
		5	PISTON SPRING WASHER	58	44876	20	BOLT- 1/4-20 X 1.38
14	2003005	1	ARM-TRUNNION	59	50002	2	PIN-.5 OD X .43 ID X .750
15	9008000-0126	1	SEAL-LIP	62	50254	1	ARM-CONTROL
17	2000015	1	GUIDE-SLOT	63	50281	2	PUCK-DAMPENER
18	50449	1	SHAFT-MOTOR	64	50018	1	SET SCREW
18	50552	1	BEARING-THRUST 42X68X16	66	50277	1	SPRING
23	70082	1	BLOCK-CYLINDER ASS'Y.	69	50284	1	5/16-24 STUD
		1	BLOCK-CYLINDER	92	2003014	1	SPRING, BLOCK
		7	PISTON	93	2003017	1	WASHER, BLOCK THRUST
		7	PISTON SPRING	98	50137	2	SLEEVE BEARING
		7	PISTON SPRING WASHER	99	50941	2	SEAL, LIP 0.75X1.00X0.156
24	45074	1	SEAL-LIP 10X25X7	113	70109	1	CAP-VENT ASSEMBLY
25	2003655	1	ACTUATOR-BYPASS			1	CAP-POPPET VALVE
26	70250	1	CENTERSECTION ASSEMBLY KIT	114	70110	1	PLASTIC VENT
		1	BYPASS PLATE			1	FITTING-O RING ASSEMBLY
		2	CHECK PLUG ASSEMBLY			1	O-RING
		1	CENTERSECTION			1	PLASTIC HOSE FITTING
		1	DU BEARING	119	50278	1	SPACER
		3	BOLT, 3/8-24 X 2.5	125	50307	1	FAN
		1	BUSHING	128	51173	1	PULLEY
27	45075	1	SEAL-LIP 26X42X8	127	44276	3	SCREW, 1/4-20 X 1-1/2
28	50007	1	RING-RETAINING	128	43178	3	NUT, 1/4-20
29	44872	2	WASHER-26X35X1	129	43177	3	LOCK WASHER
30	2003554	1	JAM NUT	130	50259	3	SPACER
34	44954	1	OIL FILTER ELEMENT	134	44142	1	CASTLE NUT, 5/16-24
35	50270	1	ARM-BYPASS	135	44101	1	COTTER PIN
36	44870	1	RING-RETAINING	139	50431	1	COMPRESSION SPRING
37	44613	1	ARM-ACTUATING	140	50269	1	NUT, HEX 5/16-24
38	44881	2	PIN-ACTUATING	142	50564	2	CHECK PLUG ASSEMBLY
39	50316	1	BOLT-5/16-24 X 1-3/4	144	50550	1	BUSHING
40	50317	1	NUT-HEX LOCK 5/16-24 UNJC	145	44133	1	HEX NUT 1/2-20 (PATCH)
41	70135	1	BRAKE ROTOR/STATOR KIT	146	51172	1	SHAFT, AXLE
		4	BRAKE STATOR	147	70418	1	FAN/PULLEY KIT
		2	BRAKE ROTDR			1	FAN
						1	PULLEY
						3	SCREW, 1/4-20 X 1-1/2
						3	NUT, 1/4-20
						3	LOCK WASHER
						3	SPACER
						1	HEX NUT 1/2-20 (PATCH)
148	50928	1	SEALANT			1	SEALANT
149		77az	20W-50 OIL			1	20W-50 OIL
150	70312	1	SEAL KIT			1	SEAL KIT
151	50416	1	GREASE			1	GREASE



P.2 of 2. 70419-S1